



NATIONAL FOOD PRODUCTS CO.

CODE:
PLA/QAD/DS -
3

QUALITY SYSTEM FORMS

ISSUE DATE:
10-June-2017

Product Data Sheet
Thermoforming

ISSUE NO.: 4

CODE

RCN5114250WHIN700-1000

PAGE: 1/1

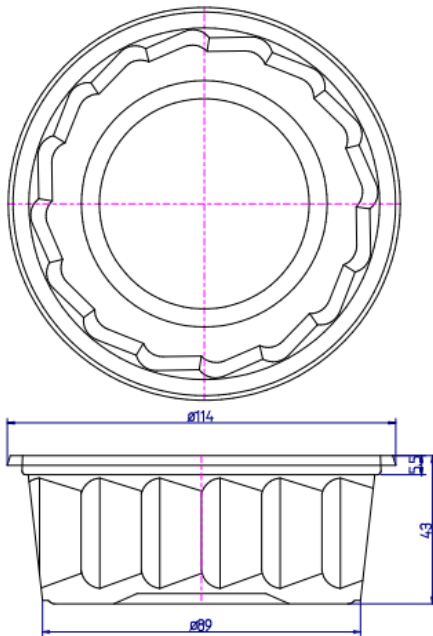

Item	PP ROUND CNT 250ML 114D WHT
Material:	Polypropylene
Color	white
Unit Weight:	7.0 g ± 0.2g

Quantity	1000 Pcs. /Carton
Carton Size	47x37.5x56 cm
Poly bag	yes

Dimensions in "mm" (Not to scale)
Tolerance ± 0.3 mm

Issued by: QC MPC