



NATIONAL FOOD PRODUCTS CO.

CODE:  
PLA/QAD/DS -  
3

QUALITY SYSTEM FORMS

ISSUE DATE:  
10-June-2017

Product Data Sheet  
Thermoforming

ISSUE NO.: 4

CODE

RCN5014200WHR1600-1000

PAGE: 1/1

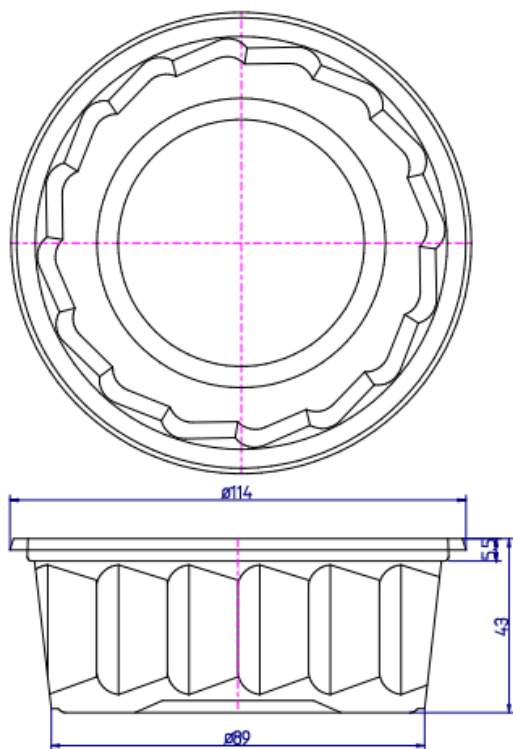

Item	PP ROUND CNT 200ML 114D WHT
Material:	Polypropylene
Color	white
Unit Weight:	6.0 g $\pm$ 0.2g

Quantity	1000 Pcs. /Carton
Carton Size	47x34.5x56 cm
Poly bag	yes

Dimensions in "mm" (Not to scale)
Tolerance $\pm$ 0.3 mm

Issued by: QC MPC